

# Force Washer Cell - FW (High Temperature)

150/300 kN

## Caution

- Do not pull on or carry sensor by cable.
- Any tampering or removal of cover, cable and/ or connector will void warranty.

## Do's

## Mounting

## Don't's

1

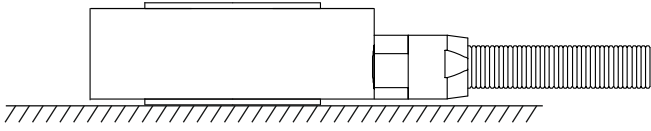

- Flat and even surface required.

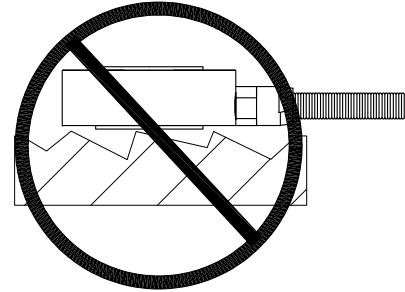

2

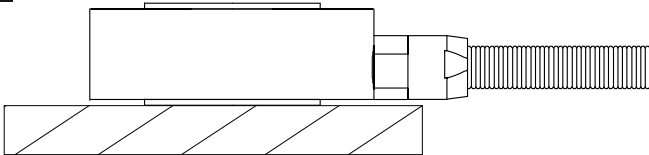

- Maintain clean surface.

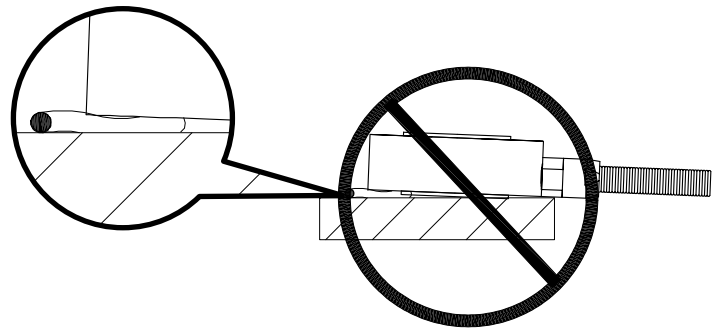

3

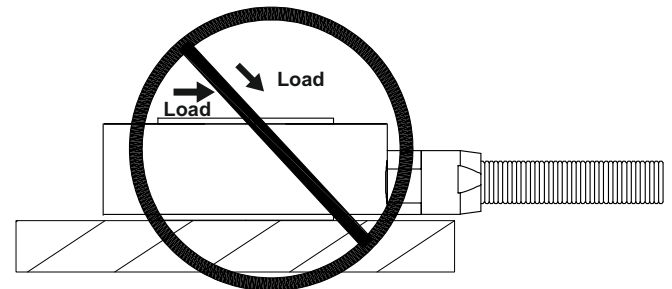
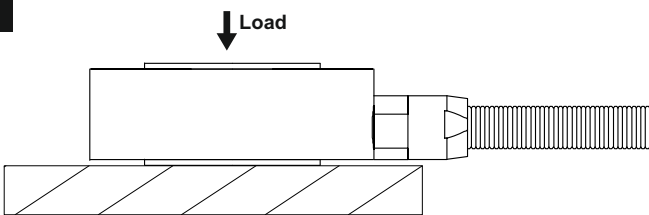

4

## Nomenclature

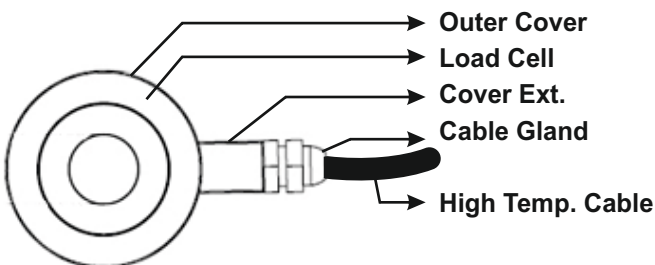

5

## Orientation

Top Side



Bottom Side

6

## Transit Protection

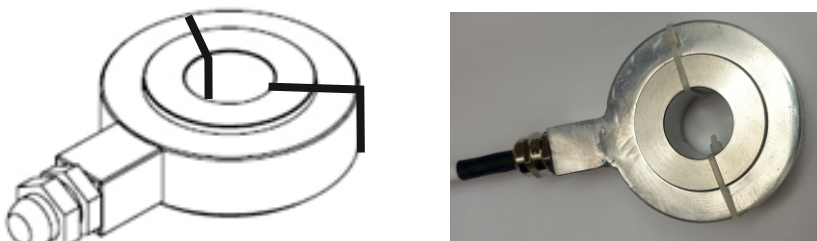

Cable tie fixed for Handling only  
(Remove before actual mounting of load cell use)

## Free cable ends

Wire	Function
Red	Excitation Positive (Exc +Ve)
Black	Excitation Negative (Exc -Ve)
Blue	Signal Positive (Sig +Ve)
Grey	Signal Negative (Sig -Ve)



**SeethaRam**  
Mechatronics Pvt Ltd  
Bridging Gaps in Technology  
www.seetharam.in

## Nomenclature

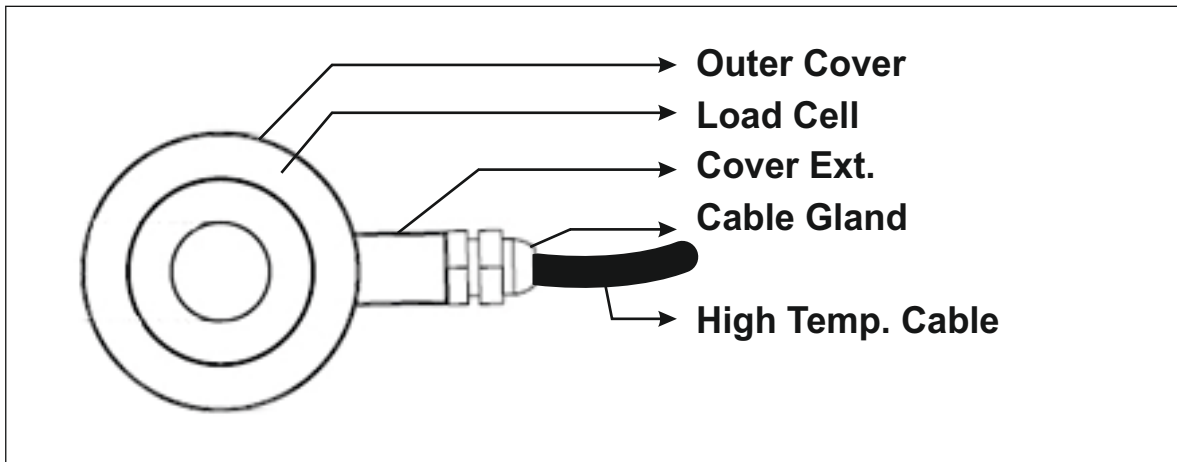

## Orientation

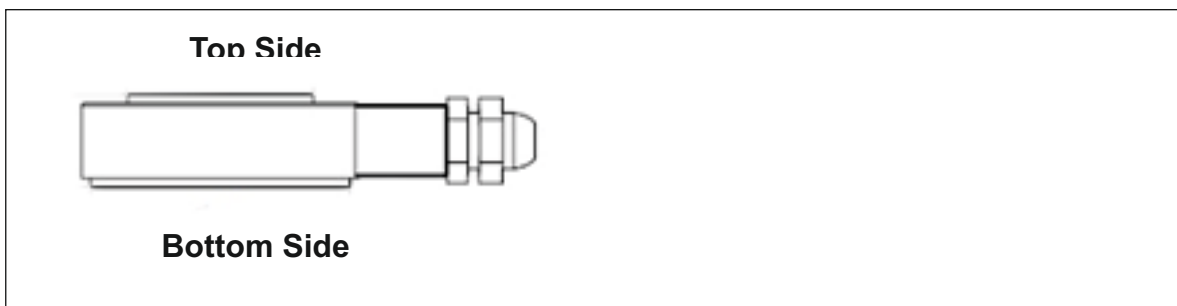

## Transit Protection

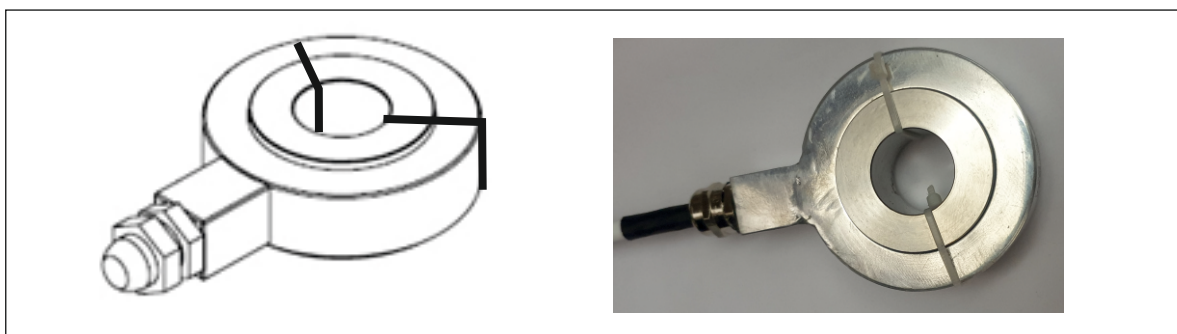

**Cable tie fixed for Handling only  
(Remove before actual mounting of load cell use)**