

# Force Pancake Male Thread - FPMT

## Pancake Tension Load Cells

### FEATURES

- Compression or Tension Load Cell.
- These load cells are extremely small and lightweight. Protection Class IP67.



### TECHNICAL SPECIFICATION

Model	FPMT
Rated capacity(R.C.)	20, 50, 100, 200, 500kgf, 1tf, 2tf
Rated output(R.O.)	2mV/V±0.4%
Nonlinearity	0.15% of R.C.
Hysteresis	0.1% of R.C.
Repeatability	0.05% of R.C.
Zero balance	±2% of R.O.
Temp. effect on rated output	±0.01% of LOAD/10°C
Temp. effect, on zero balance	0.05% of R.O./10°C
Temperature range, compensated	-10~70°C
Temperature range, safe	-10~80°C
Terminal resistance input	350Ω±30Ω
Terminal resistance output	350Ω±2Ω
Insulation resistance bridge/case	2000MΩ
Excitation recommended	10V (max. excitation 15V)
Safe overload	120% R.C..
Cable length	Ø5mm 4core, 3m

### WIRING INFORMATION

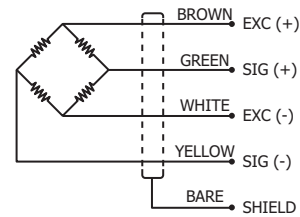

### DIMENSION DETAILS

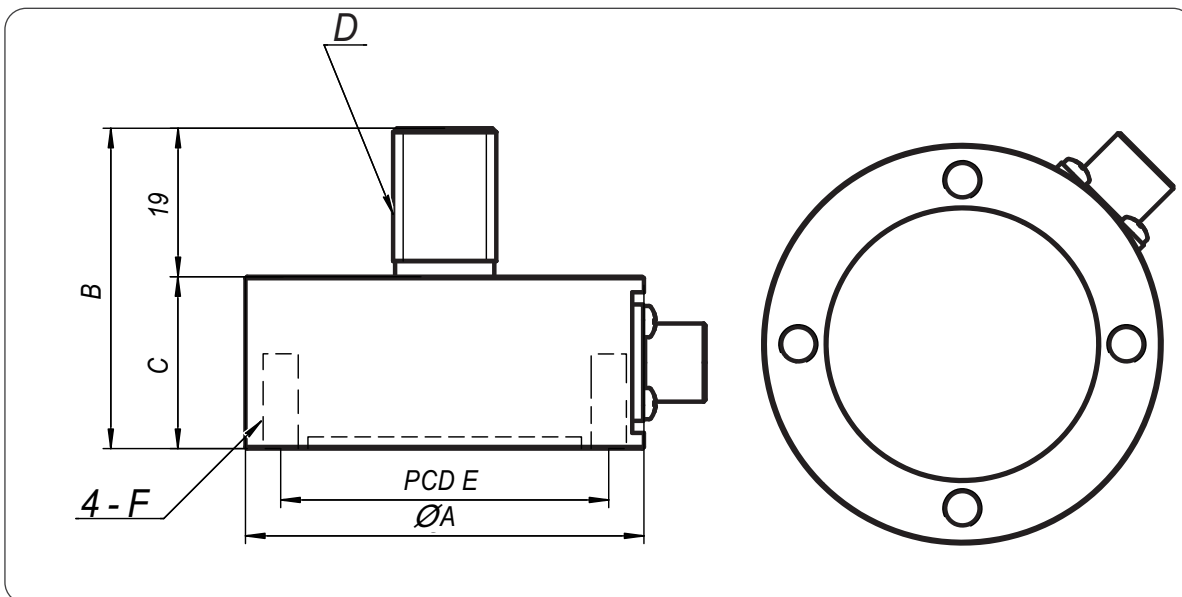

### DIMENSION TABLE

Unit : mm

Capacity	A	B	C	D	E	F
20, 50, 100, 200, 500Kgf, 1Tf, 2Tf	51	41	22	M12x1.25	42	M5xDP12

Specifications are subject to change without Prior notice